

**N55UP Dragonfly Pitch Trim Wiring**  
**Dave Morris 01Feb2004**

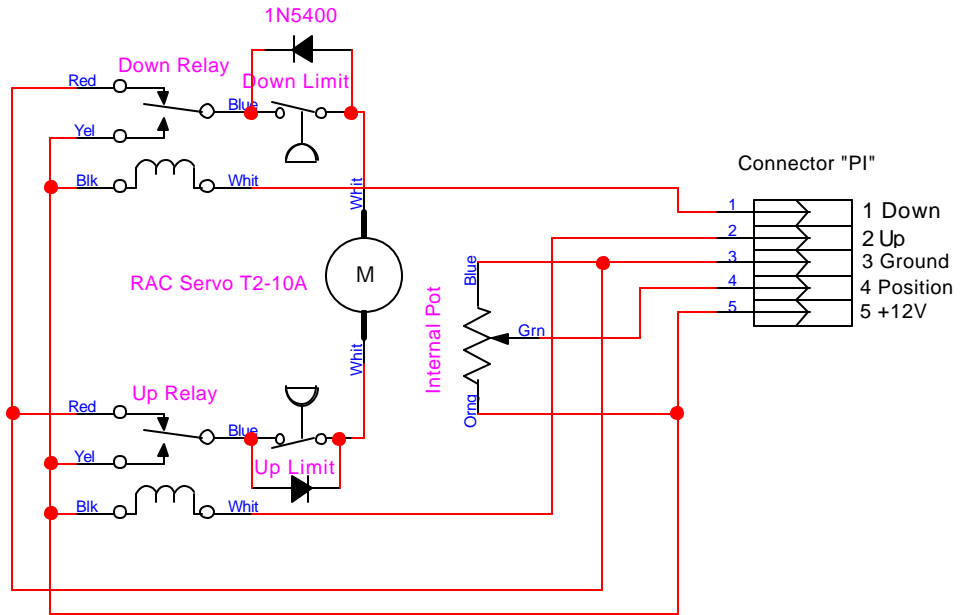

**Notes:**

1. 12VDC (pin 5) should be fed from a 2A fuse and a power switch to allow the motor to be disabled in the event of a failure.
2. Joystick UP and DOWN switches (pins 1 & 2) are momentary to ground.
3. The Alex Strong servo does not have any built-in limit switches, so we have microswitches at each end to limit maximum travel.
4. All wires are 20 AWG
5. Connector "PI" is 5-pin male Molex.
6. Relays in this installation happen to be Bosch part number 0332209150 automotive fuel pump relays with an 84 Ohm coil (142 mA) with 20/30A contacts, and wire colors indicated on this schematic are those built into the relay socket.