

N75UP Dragonfly Electrical System Schematic

Dave Morris 03June2005

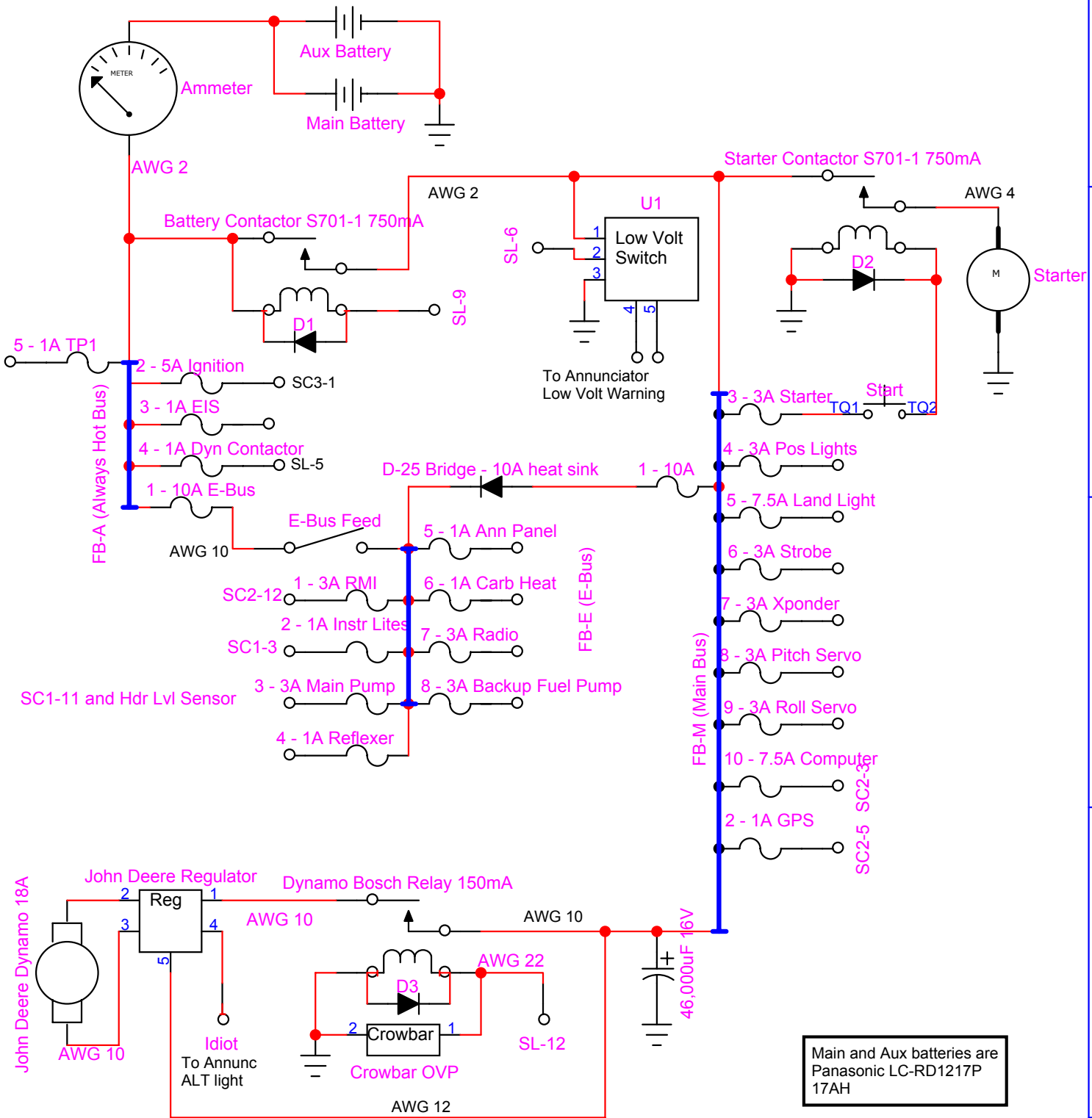

Main and Aux batteries are Panasonic LC-RD1217P 17AH

1. In case of dynamo overvoltage, the crowbar will short-circuit, popping the push-pull breaker and taking the dynamo off-line.
2. In case of dynamo failure, pull the Battery switch and activate the E-Bus Feed switch to power the E-Bus for the duration of the flight, until the field can be safely made.
3. Alternatively, leave the Battery switch on but turn off individual circuits until the Ammeter shows an acceptable load for the remaining flight.