

N75UP Dragonfly Center Switch Panel

Dave Morris 03June2005

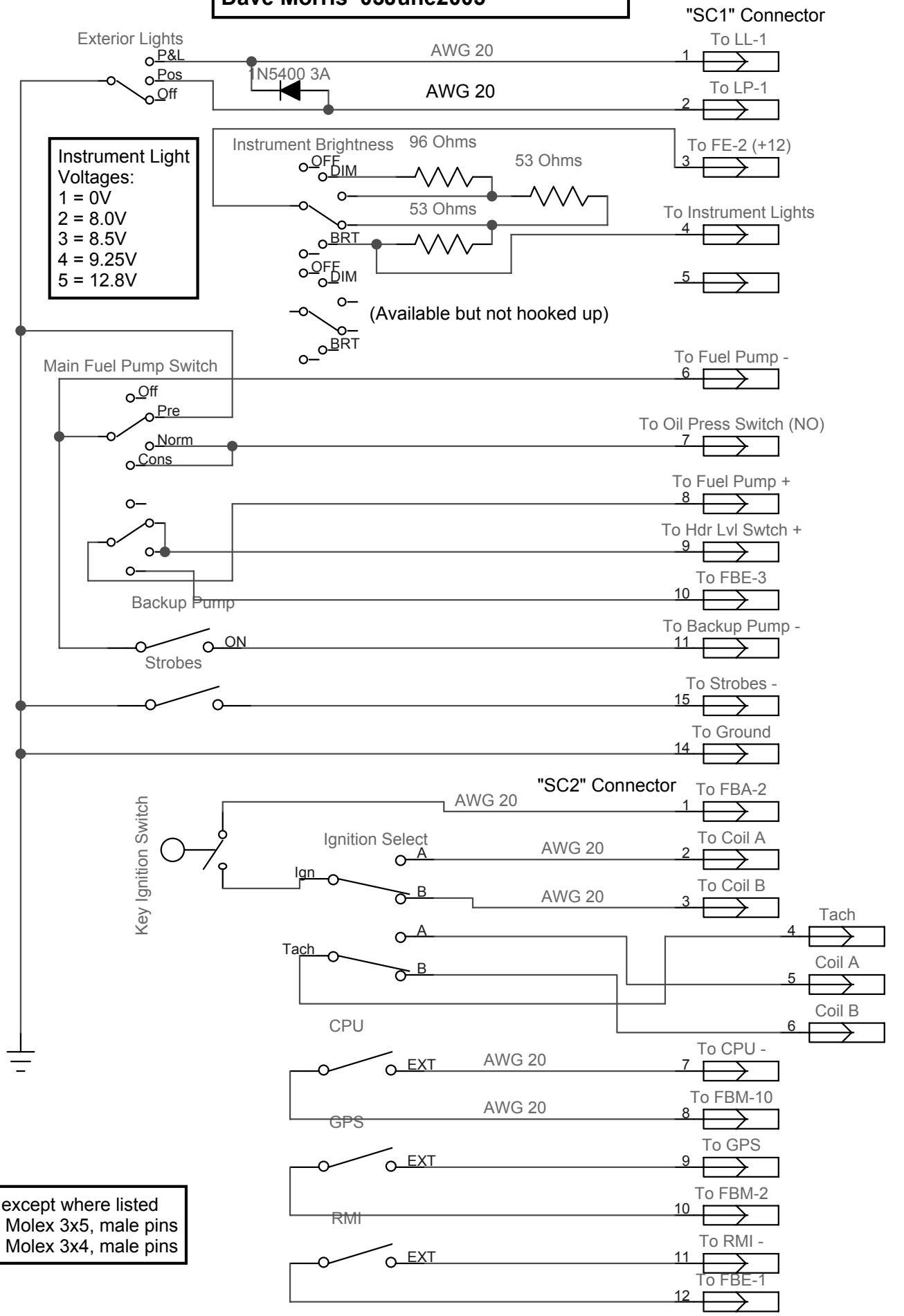

Instrument Light Voltages:
 1 = 0V
 2 = 8.0V
 3 = 8.5V
 4 = 9.25V
 5 = 12.8V

All AWG 22 except where listed
 SC1 is male Molex 3x5, male pins
 SC2 is male Molex 3x4, male pins